

For your safety - always



in each  
case

Your wish is our command

## Contents

---

### Safety with electric switches

Pages 3-7

Safety with electric switches

Basic information

„Fixed product“ systems

Direct and indirect shut-down

Features of GIFAS system and safety switches



### GIFAS system and safety switches

Pages 8-10

Main system switches with emergency shut-off function

„Direct“ safety switches for revision

„Indirect“ safety switches



### Combinations

Pages 11-13

Safety and control switch combinations

Combinations of multiple safety switches

Special combinations



### Special versions and practical examples

Pages 14-19

Steel supports/consols

Snapping-in emergency shut-off switch

Motor protection switch

Practical examples



## Safety with electric switches

---

### Basic information

In production and technical operative systems, all measures must be taken to prevent accidents at work in line with art. 82 of the Law on Accident Prevention (German: *Unfallverhütungsvorschriften UVV*). This regulation is intended to help prevent accidents at work. The areas of responsibility have been defined with greater clarity according to the new standards.

### Safety concept

Very different requirements for the safety concept can arise depending on the operating mode of a system. Safety should be guaranteed both in normal operation and special operating modes. In addition to the **safety measures against electrical dangers** (due to the flow of electrical energy), measures should also be taken against **non-electrical risks** (e.g. due to movements).

### Laws, regulations, standards

Detailed information on this subject are given in the following laws, regulations and standards:

- EC Machines Directive 98/37/EC, Appendix I, 1.6.3
- EN 292-2: 1995
- EN 60204-1:1997, point 5.4
- EN 1037:1995, Safety of machines
- Disconnection from the power supply and energy dissipation
- Avoiding accidental starts
- Ordinance on the prevention of accidents and work-related illnesses, Art. 30
- SN 411122:1993 (SEV 1122.1993), Measures in low-voltage installations to protect against non-electrical risks in productive and operational technical systems



### Correct maintenance – Safe shut-down

Better safe, than sorry. The maintenance engineer is certain that he has definitely shut down the machine. Suddenly it starts up, because ...? To avoid this, various regulations and recommendations have been released (Switzerland: SUVA/SEV, FRG: VDE/BG).

GIFAS-ELECTRIC has tackled this problem and has created a basic range of system and safety switches to make your work easier and to keep you safe.

## Basic information

---

### Development of the technology

Previously, electrical products normally used to have a considerably simpler design. For example, lathes were only actuated using a single motor protection switch. Other settings were carried out mechanically. Today, machines and systems have complex controls, servo and auxiliary units through to entire robots. This shows that over the past few years, the conditions for protecting against undesirable operating conditions have become considerably more complex. For the safety of personnel in particular, new requirements have therefore arisen to provide sufficient protection.

### Accident prevention with switching equipment

This brochure covers the prevention of accidents primarily using suitable switching equipment. The ordinances, regulations and recommendations regulate both protection against electrical risks and protection against non-electrical risks.

### Responsibility

Anyone constructing or installing equipment and devices is responsible for ensuring that all safety conditions are met.

### Electrical and non-electrical risks

In production and technical systems, electrical risks to persons can arise due to the flow of the electrical energy. All other risks for persons arising on these systems come under the heading of non-electrical risks.

#### Electrical risks

For protection against electrical risks, the Technical Standard on Low Voltage (NIN) from the Swiss Association of Electrical Engineering SEV 1000-1 (FRG: Association of German Electrical Engineers, VDE) and other ordinances, regulations, guidelines and standards also apply to the relevant systems.

#### Non-electrical risks

Non-electrical risks can include dangerous movements for example – or generally dangerous changes in operating condition – that are generated via electrical energy. It must be possible to prevent these via the reliable switching and controlling of the relevant flow of energy.



### Scope

The standards differentiate between production equipment and operating equipment. They are defined as follows:

a) The production systems include equipment used to change the form, condition, properties, behaviour, composition, appearance and/or position of forces, materials, objects or living organisms such as construction equipment, tooling machines, machining and processing equipment, packaging machines, surface treatment equipment, reshaping equipment, etc.

b) The operating systems include equipment which are required in addition to the actual production equipment in order to maintain operation, such as the building and its doors, windows, heating, ventilation, water supply etc., power conversion devices, transport devices, material and warehouse stores with the equipment, etc.

### Legal principles and regulations

The principles of the designs relate to the authorities mentioned and the regulations, ordinances and standards issued by those authorities, based on German Law article 82 on accident prevention (Germany: Accident Prevention Regulations).

#### Authorities responsible

ESTI	Eidgenössisches Starkstrominspektorat (Swiss Confederation High Voltage Inspectorate)
ASEV	Schweizerischer Elektrotechnischer Verein (Swiss Association of Electrical Engineering)
SUVA	Schweizerische Unfallversicherungsanstalt (Swiss Association for Accident Prevention)
VDE	Verband Deutscher Elektrotechniker e.V. (Association of German Electrical Engineers)
BG	Berufsgenossenschaft der Feinmechanik und Elektrotechnik (Trade Association for Precision and Electrical Engineering)

#### Standards

NIN	Niederspannungs-Installationsnormen (Low Voltage Installation Standards)
SN SEV	Technical standards
VUV	Verordnung über Unfallverhütung (Ordinance on Accident Prevention)
CEI	European standards
UVV	Unfallverhütungs-Vorschrift (Accident Prevention Ordinance)
DIN-VDE	Regulations
VDE	Standards

#### Source

SUVA	Publication on safety switches, order no. CE93-9.d
SEV	1122.1993

## „Fixed product“ systems



### Integrating the safety switch into an overall system

#### (created from functional units)

The system should be divided into groups of functional units for a specific operating purpose.

A technical system or a complex production machine should be divided up into appropriate functional units at the planning stage, and one safety switch should be assigned to each unit. This means that operational and safety requirements for the machine are met (e.g. with parallel production lines the option to shut off individual lines without impairing the overall production as otherwise there would be a risk of the safety switch not being used). This means that in the event of a fault or a repair, limited production can be maintained on another parallel path, or parts of the system can continue to be operated.

It must be possible to switch off each functional unit using a separate safety switch (VUV, Art. 30).

With extensive functional units the safety switches must be fitted so that one safety switch can be found in the immediate vicinity of every intervention point.

### The safety shut-down

Safety shut-down devices must interrupt the flow of power so that no dangerous changes in operating condition can be initiated either through incorrectly entered or faulty control signals.

The safety shut-down device permits persons who need to intervene in the non-electrical danger areas of the system to prevent unintentional changes in the operating status (e.g. initiating a dangerous movement). With simple systems, the system switch can be used to shut down the power supply. However, very often the entire power supply must not be shut down because for example safety devices and control or checking devices must remain in operation, or because with the intervention to be carried out, it must be possible to carry out changes in the operating status intentionally with the special operating control. When designing safety shut-down devices, it is essential to ensure that all power sources are shut off and all stored energy is dissipated that might cause a dangerous change in operating condition. The safety shut-down can carry out the shut-down, depending on the conditions, either directly using a safety switch that shuts down all pole lines, or with an indirect shut-down procedure.

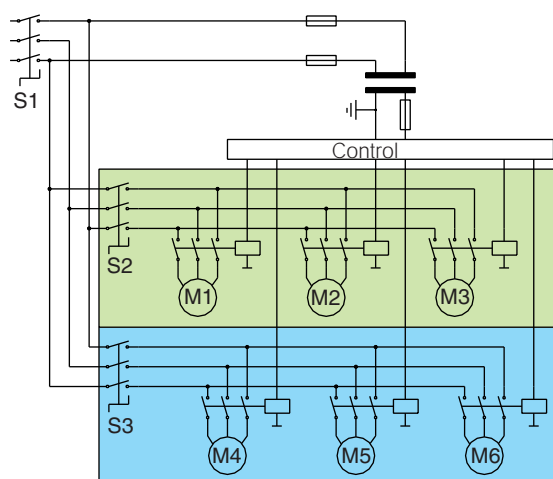
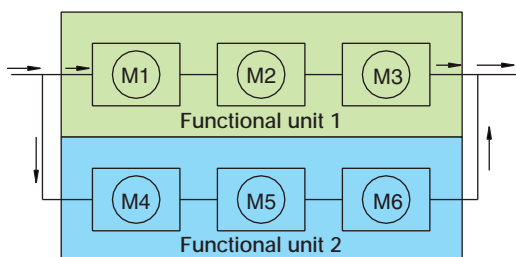

- S1 Main switch/system switch
- S2 Safety switch for functional unit 1
- S3 Safety switch for functional unit 2

# Direct and indirect shut-down



**Direct shut-down (figure 1)**

With direct shut-down the supply line to a motor or a system is shut down on all poles directly in the main power circuit. This is achieved with a switch with the two defined positions „0-I“, which conforms to the requirements for a safety switch (see right).

**Indirect shut-down (figure 2)**

With indirect shut-down the main power source is switched via a contactor, for example. The indirect shut-down consists of a safety switch (as a control switch) and a safety contactor. The special requirements both for the safety switch and for the safety contactor must be fulfilled.

Safety shut-down devices must have a clearly detectable shut-down which may only be displayed when the power supply has been shut down reliably. When the indirect shut-down device, the actual safety shut-down is carried out via the safety contactor. A feedback lamp fitted directly onto the safety shut-down device actuator must therefore indicate (by lighting up) that the contacts on the safety contactor are actually open.

### The safety switch

With an issue date of May 2000, the SUVA/CNA/INSAI permits a revised regulation which describes which basic requirements a safety switch must fulfil. In Germany the relevant regulations VDE 01-1996 apply.

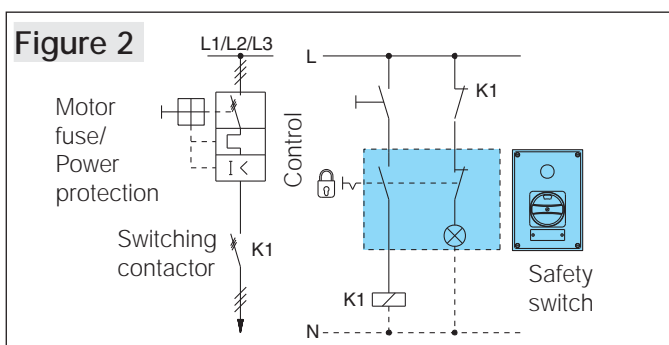
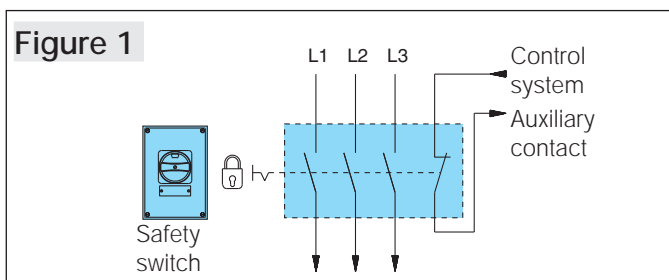

### The most important features

#### Basic requirements

In technical devices representing a risk in special operating modes (troubleshooting, repairs, maintenance, cleaning, etc.), a safety switch must be installed close to each functional unit.

#### The safety switch must meet the following requirements: It must...

- have priority over the switching devices in all operating modes;
- interrupt the supply of all dangerous power sources to the system and dissipate the dangerous stored power in the system (e.g. vent pneumatics) or store it safely (EN 1037, point 5.3.1.2);
- be labelled (a diagram must be given, for example, showing which area of the system is rendered inactive by the safety switch);
- have a positive effect and have forced opening contacts;
- normally have two switch positions, e.g. „0“ (OFF) and „I“ (ON) (when using the safety switch as an emergency stop switch, only two positions are permitted);
- be possible to secure it against unintentional and accidental re-actuation in the OFF positions using multiple (at least 3) personal padlocks;
- be easily accessible without causing danger;
- be positioned so that the part of the system shut down can be viewed;
- always be fitted in immediate proximity to the intervention point (in other words, on site);
- with extensive systems or systems distributed across multiple rooms, be fitted at multiple points and wherever interventions are carried out on the system;
- be designed in black or grey (exception: if the safety switch is also being used as an emergency stop switch, it must have a red handle and a yellow background);
- be designed to prevent re-actuation in the shut-down OFF position.

#### With the indirect shut-down, the following conditions must be met:

- The actual shut-down must be indicated (e.g. using a white indicator light, identified with „0“ or „OFF“).
- This display must be safe (e.g. use contactors with forced contacts).
- When the safety switch is shut down, it must not be possible to actuate the indirectly actuated switching elements via manual intervention or another other outside influence.

## Features of GIFAS system and safety switches

---



The GIFAS system and safety combinations are designed for systems where mechanical strength, tightness, chemical resistance, sufficient connection space and visual impression are important. Our complete range of hard rubber casings allow us to manufacture customer requirements for on-site combinations flexibly. The most important features of the GIFAS switch combinations are shown on this page.

### Casing specifications

#### Material

GIFAS hard rubber casings are made from a special butyl rubber mixture, and the cover from polycarbonate. More information on the casings, such as dimensions, assembly holes, etc., can be found in the brochure "Power distribution boxes", index 1.

#### UV resistance

The pale grey or black designs as well as the varnished rubber casings are permanently UV-resistant. Coloured casings such as orange or red only offer limited UV-resistance.

#### Halogen-free

Completely halogen-free and not contaminated with silicone materials.

#### Behaviour in fire

Barely flammable and self-extinguishing.

#### Resistance to chemical materials

The hard rubber is in general resistant to alkalis and acids used in industry.

#### Resistance to aging

Years of use has not resulted in any problems with aging (becoming hard or brittle, etc.).

#### Casing materials

In addition to the GIFAS hard rubber casings, switch casings in steel plate, stainless steel A2/A4 and in polyester are also available.

### Switching and display elements

We assemble the products specified by the customer in the relevant designs, outputs and voltages. Our standard products are Sälzer, Kraus & Naimer switches, and main system switches (0-1) also from the manufacturer ABB. As display elements we use Télémécanique (LED) and EAO.

### Terminals

The fitting is carried out according to the diagram with the required terminals, e.g. series or cage tension spring terminals. Our standard products are Wago, Woertz and Phönix terminals.

### Screwed cable glands

High quality screwed cable glands perfect to the finest detail are used and assembled individually according to the diagrams/drawings.

### Assembly fitting types

The screw canals in the casing are outside the sealed area to ensure correct seal and safety insulation. The rapid assembly is made even easier using the rust-free fitting brackets or plates to match the casing.

### Corrosion protection

The cover screws are always made from stainless steel **V4A**. Assembly accessories such as brackets are made from zinc-plated, A2 or A4 steel, according to the customer's requirements.

### Labelling

With our engraving machine we label the combinations according to your specifications and permanently affix the engraved signs.

### Protection rating

Seal groove, sealing part and rubber seal guarantee protection rating IP65 on the casing. Depending on the product used with the switch and display elements, the protection ratings vary from IP54 to IP65.

# Main system switches with emergency shut-off function



## Type 1212 Sizes 125 • 125 • 76 mm



Item	Colour	Power	Output	C.-glands
50630	pale grey	3 - 16 A	5.5 kW	2 x M20
33302	black	3 - 16 A	5.5 kW	2 x M20

Switch type SÄLZER

For drive units where the main system switch can also be the emergency stop switch.

Pressing the emergency stop switch will shut down the power supply to the entire system.

- Main switch with red handle on yellow background, can be locked in the initial position
- Switch **3-pole** with N and PE terminals
- Rated operating output at 50–60 Hz, AC23, 400/415 V
- Rated operating output AC22, 400/415 V
- Standard casing colour pale grey RAL 7035, also available in black

## Type 1212 Sizes 125 • 125 • 76 mm

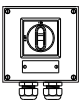

Item	Colour	Power	Output	C.-glands
53988	pale grey	3 - 16 A	7.5 kW	2 x M20
53615	black	3 - 16 A	7.5 kW	2 x M20

Switch type ABB

## Type 1812 Sizes 125 • 180 • 90 mm

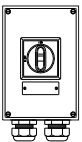

Item	Colour	Power	Output	C.-glands
50632	pale grey	3 - 25 A	7.5 kW	2 x M25
33304	black	3 - 25 A	7.5 kW	2 x M25
50633	pale grey	3 - 32 A	11 kW	2 x M25
33305	black	3 - 32 A	11 kW	2 x M25

Switch type ABB

## Type 3020 Sizes 200 • 300 • 110 mm

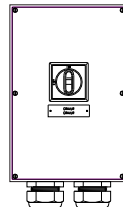

Item	Colour	Power	Output	C.-glands
50636	pale grey	3 - 80 A	30 kW	2 x M40
33314	black	3 - 80 A	30 kW	2 x M40
50637	pale grey	3 - 100 A	37 kW	2 x M40
33315	black	3 - 100 A	37 kW	2 x M40

Switch type ABB

## Type 1616 Sizes 160 • 160 • 90 mm

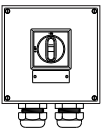

Item	Colour	Power	Output	C.-glands
50634	pale grey	3 - 45 A	15 kW	2 x M32
33308	black	3 - 45 A	15 kW	2 x M32

Switch type ABB

## Type 3800 Sizes 250 • 360 • 133 mm

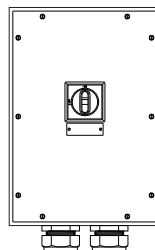

Item	Colour	Power	Output	C.-glands
50638	pale grey	3 - 125 A	45 kW	2 x M40
33316	black	3 - 125 A	45 kW	2 x M40
56213	pale grey	3 - 160 A	75 kW	2 x M50
56216	black	3 - 160 A	75 kW	2 x M50

Switch type ABB

## Type 2516 Sizes 160 • 250 • 90 mm

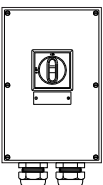

Item	Colour	Power	Output	C.-glands
50635	pale grey	3 - 63 A	18.5 kW	2 x M32
33310	black	3 - 63 A	18.5 kW	2 x M32

Switch type ABB

**Your specific requirements?**  
Allow us to offer you a custom-built solution.

# „Direct“ safety emergency switches



## Type 1212 Sizes 125 • 125 • 76 mm



Item glands	Colour	Power	Output	C.-
50643	pale grey	3 - 16 A	5.5 kW	2 x M20
33320	black	3 - 16 A	5.5 kW	2 x M20

Switch type SÄLZER

Safety, inspection or maintenance switches for enabling electrical systems or system parts.

- Safety switches with black or grey handle and grey base, can be locked in the OFF position, e.g. using padlocks.
- Safety switch **3-pole** with N and PE terminals
- Auxiliary contacts **1make + 1break**.
- Rated operating output at 50–60 Hz, AC23, 400/415 V
- Rated operating output AC22, 400/415 V
- Standard casing colour pale grey RAL 7035, also available in black

## Type 1212 Sizes 125 • 125 • 76 mm

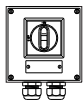

Item glands	Colour	Power	Output	C.-
54025	pale grey	3 - 16 A	7.5 kW	2 x M20
54024	black	3 - 16 A	7.5 kW	2 x M20

Switch type ABB

## Type 1812 Sizes 125 • 180 • 90 mm

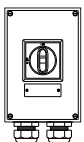

Item glands	Colour	Power	Output	C.-
50645	pale grey	3 - 25 A	7.5 kW	2 x M25
33324	black	3 - 25 A	7.5 kW	2 x M25
50648	pale grey	3 - 32 A	11 kW	2 x M25
33326	black	3 - 32 A	11 kW	2 x M25

Switch type ABB

## Type 3020 Sizes 200 • 300 • 110 mm

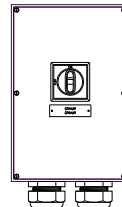

Item glands	Colour	Power	Output	C.-
50652	pale grey	3 - 80 A	30 kW	2 x M40
33334	black	3 - 80 A	30 kW	2 x M40
50653	pale grey	3 - 100 A	37 kW	2 x M40
33335	black	3 - 100 A	37 kW	2 x M40

Switch type ABB

## Type 1616 Sizes 160 • 160 • 90 mm

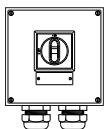

Item glands	Colour	Power	Output	C.-
50649	pale grey	3 - 45 A	15 kW	2 x M32
33328	black	3 - 45 A	15 kW	2 x M32

Switch type ABB

## Type 3800 Sizes 250 • 360 • 133 mm

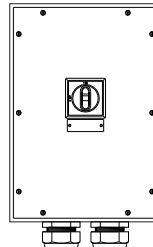

Item glands	Colour	Power	Output	C.-
50654	pale grey	3 - 125 A	45 kW	2 x M40
33336	black	3 - 125 A	45 kW	2 x M40
58602	pale grey	3 - 160 A	75 kW	2 x M50
58603	black	3 - 160 A	75 kW	2 x M50

Switch type ABB

## Type 2516 Sizes 160 • 250 • 90 mm

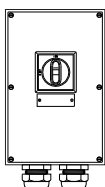

Item glands	Colour	Power	Output	C.-
50651	pale grey	3 - 63 A	18.5 kW	2 x M32
33330	black	3 - 63 A	18.5 kW	2 x M32

Switch type ABB

**Your specific requirements?**  
Allow us to offer you a custom-built solution.

# „Indirect“ safety switches



Version A

Version B

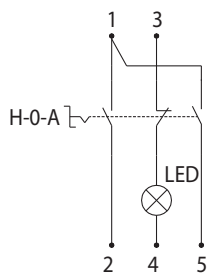
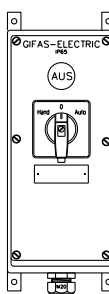
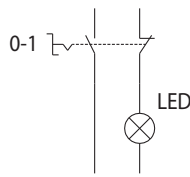
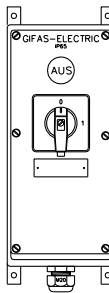
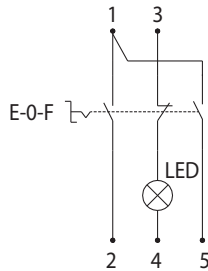
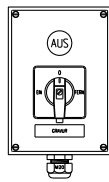
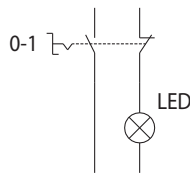
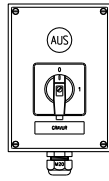

Item	LED	Switch
52693	24 V	A
49164	230 V	A
58605	24 V	B
58606	230 V	B

**Casing:** Type 1812  
**Sizes:** 125 • 180 • 90 mm  
**Colour:** Pale grey  
**Switch type/function:**  
**A** = Locking rim 0-1 1make+1break  
**B** = Handle lock 0-1 1make+1break unwired

Item	LED	Switch
49670	24 V	A
49672	230 V	A
58608	24 V	B
58609	230 V	B

**Casing:** Type 1812  
**Sizes:** 125 • 180 • 90 mm  
**Colour:** Pale grey  
**Switch type/function:**  
**A** = ON-OFF-REMOTE locking rim  
**B** = Handle lock ON-0-REMOTE wired on terminals

Item	LED	Switch
49663	24 V	A
49666	230 V	A
58610	24 V	B
58611	230 V	B

**Casing:** Type 2812  
**Sizes:** 120 • 268 • 132 mm  
**Colour:** Pale grey  
**Switch type/function:**  
**A** = Locking rim 0-1 1make+1break  
**B** = Handle lock 0-1 1make+1break unwired

Item	LED	Switch
49652	24 V	A
49657	230 V	A
58612	24 V	B
58616	230 V	B

**Casing:** Type 2812  
**Sizes:** 120 • 268 • 132 mm  
**Colour:** Pale grey  
**Switch type/function:**  
**A** = locking rim MANUAL-0-AUTO  
**B** = handle lock MANUAL-0-AUTO wired on terminals

## Technical info

### „OFF“ indicator lamp:

„LED“ modules with the following features:

- extremely high service life: at 25° C 100,000 hours
- for voltages 24 V AC/DC, 120 V AC and 240 V AC

### Front handled switches:

Version A:

- Safety switch with **locking rim**
- can be locked using three padlocks

Version B:

- Safety switch with **handle lock**
- Advantage = clear labelling
- can be locked using three padlocks

### Switch labels

We label your switch positions according to your specifications (see examples)

- 0-1
- MANUAL-0-AUTO
- MANUAL-0-REMOTE
- REMOTE-0-ON
- LOCAL-OFF-REMOTE
- AUTO-0-ON
- TEST-0-REMOTE
- INSP-OFF-AUTO

### Screwed cable glands

- M20

### Terminals

- Wago terminals (cage clamp)

### Wiring

We supply the on-site combinations on terminals wired or unwired.

# Safety and control switch combinations



## Type 2812

Sizes 120 • 268 • 132 mm



### Component

- 1 Lockable switch „0-I“ 1make+1break
- 1 Switch „MANUAL-0-AUTO“
- 1 Signal lamp 24 V LED white „Off“
- 10 Wago terminals, 2.5 mm<sup>2</sup>
- 1 Screwed cable gland M20
- 2 Fitting brackets V4A

Item 50661 pale grey, indirect

With the safety and on-site combinations, other control and display functions can be integrated in addition to the safety switch, such as system controls with „Manual-0-Auto“ or key switches. Direct as well as indirect switches with additional controls can be integrated into the various GIFAS hard rubber casings. The practical examples shown the various switch combinations. We would be pleased to help you realise your special requirements.

## Type 2812

Sizes 120 • 268 • 132 mm

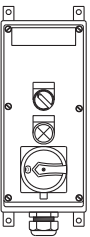

### Component

- 1 Lockable switch „0-I“ 1make+1break
- 1 Switch „ON-OFF-AUTO“
- 1 Signal lamp 24 V LED white „Off“
- 6 Terminals, 2.5 mm<sup>2</sup>
- 1 Screwed cable gland M25
- 2 Fitting brackets V4A
- 1 Ventilation filter

Item 50663 pale grey, indirect

## Type 2516

Sizes 160 • 250 • 90 mm  
no safety collar

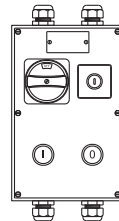

### Component

- 1 Lockable switch „0-I“ 4P 16 A
- 1 Key switch „0-I“ 1P
- 1 Kaba cylinder for key switch
- 1 Pushbutton green „I“
- 1 Pushbutton, red „0“
- 16 Wago terminals, 2.5 mm<sup>2</sup>
- 4 Screwed cable glands M20

Item 50668 pale grey, direct

## Type 2812

Sizes 120 • 268 • 132 mm

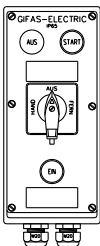

### Component

- 1 Lockable switch „MANUAL-OFF-REMOTE“
- 1 Illuminated pushbutton with 230 V LED yellow
- 1 Pushbutton, green
- 1 Signal lamp 230 V LED white
- 11 Terminals, 2.5 mm<sup>2</sup>
- 2 Screwed cable glands M20

Item 58636 pale grey, indirect

## Type 7250

Sizes 160 • 280 • 133 mm

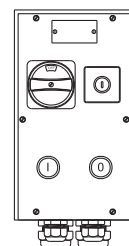

### Component

- 1 Lockable switch „0-I“ 3make+1break 32 A
- 1 Key switch „0-I“ 1P
- 1 Kaba cylinder for key switch
- 1 Pushbutton green „I“
- 1 Pushbutton, red „0“
- 11 Wago terminals, 2.5 mm<sup>2</sup>
- 4 Screwed cable glands 2xM20/2xM25

Item 50669 pale grey, direct

## Type 2516

Sizes 160 • 250 • 90 mm  
no safety collar

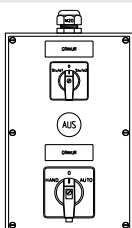

### Component

- 1 Switch „STAGE 1-0-STAGE 2“
- 1 Lockable switch „MANUAL-0-AUTO“
- 1 Signal lamp 230 V LED white
- 7 Terminals, 2.5 mm<sup>2</sup>
- 1 Screwed cable gland M20

Item 44841 pale grey, indirect

## Type 7350

Sizes 200 • 350 • 133 mm

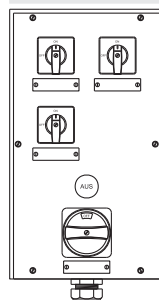

### Component

- 1 Lockable switch „0-I“ 1make+1break
- 1 Switch „MANUAL-0-AUTO“ 1P
- 1 Switch „OFF-CLOSED-AUTO“ 1P
- 1 Switch „SLIDER-FILTER-AUTO“
- 1 Signal lamp 24 V LED white
- 16 Terminals, 2.5 mm<sup>2</sup>
- 1 Screwed cable gland M25

Item 50700 pale grey, indirect

# Combinations of multiple safety switches



## Type 2516

Sizes 250 • 160 • 90 mm

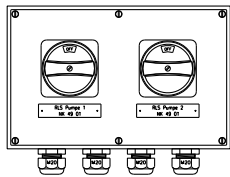

- Component**
- 2 Lockable switches „O-I“
  - 3P-20A HK 1make+1break
  - 4 Terminals, 2.5 mm<sup>2</sup>
  - 4 Screwed cable glands M20

Item 78057 pale grey

The requirements in the safety and control fields are so varied that customised solutions are virtually everyday. We would be pleased to help you realise combinations with multiple safety and control switches in the casing.

## Type 7250

Sizes 160 • 280 • 133 mm

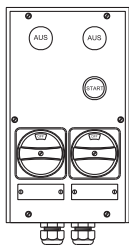

- Component**
- 2 Lockable switches „ON-OFF-REMOTE“
  - 1 Pushbutton green „I“
  - 2 Signal lamps 230 V LED white
  - 12 Terminals, 2.5 mm<sup>2</sup>
  - 2 Screwed cable glands M20

Item 50698 pale grey

## Type 7450

Sizes 266 • 370 • 133 mm

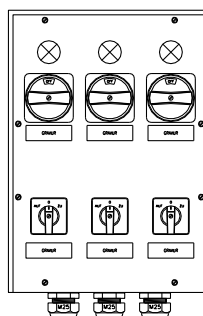

- Component**
- 3 Lockable switches „MANUAL-0-AUTO“
  - 3 Signal lamps 230 V LED white
  - 3 Switches „OFF-0-CLOSED“
  - 27 Wago terminals, 2.5 mm<sup>2</sup>
  - 3 Screwed cable glands M25

Item 58640 pale grey

## Type 3020

Sizes 200 • 300 • 110 mm

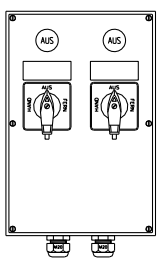

- Component**
- 2 Lockable switches „MANUAL-OFF-REMOTE“
  - 2 Signal lamps 230 V LED white
  - 10 Terminals, 2.5 mm<sup>2</sup>
  - 2 Screwed cable glands M20

Item 58637 pale grey

## Type 7750

Sizes 336 • 370 • 162 mm

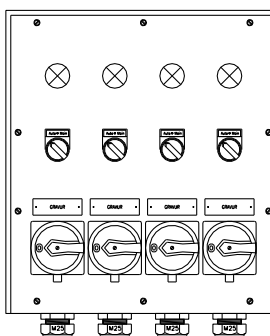

- Component**
- 4 Lockable switches „O-I“ 1P
  - 4 Selector switches „AUTO-0-MANUAL“
  - 4 Signal lamps 24 V LED white
  - 28 Terminals, 1.5 mm<sup>2</sup>
  - 4 Screwed cable glands M25

Item 58645 pale grey

## Type 7350

Sizes 200 • 350 • 133 mm

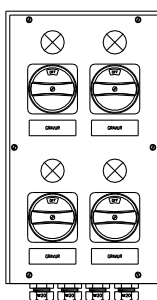

- Component**
- 4 Lockable switches „MANUAL-0-REMOTE“
  - 4 Signal lamps 230 V LED white
  - 28 Terminals, 2.5 mm<sup>2</sup>
  - 4 Screwed cable glands M20

Item 59551 pale grey

## Special combinations



### Type 3020

Sizes 200 • 300 • 110 mm

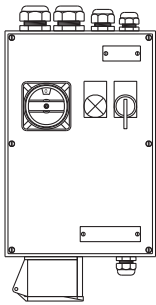

**Component**

- 1 Lockable switch „0-I“ 3P 20 A
- 1 Illuminated pushbutton
- 1 Multi-LED 24VDC
- 1 Selector switch „0-I“
- 1 Built-in socket CEE 32 A 400 V 6P+E
- 14 Series terminals 2.5 mm<sup>2</sup>
- 8 Series terminals 4 mm<sup>2</sup>
- 5 Screwed cable glands M16/M20/M25

Item 50708 pale grey

One or more high-voltage sockets as service sockets or as power connections for conversion and repair work can be integrated into the on-site combinations. Combinations are useful with external applications in particular, where appropriate mounted on a support. With the practical examples, we intend to show you which combination options are possible by using small and large casings.

Protection rating (empty casing): IP65  
Sockets: IP44/IP65  
Switch/display list: IP65

### Type 7450

Sizes 266 • 370 • 133 mm

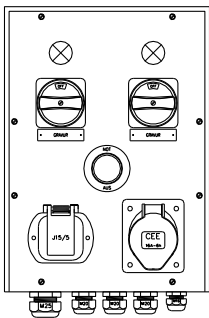

**Component**

- 2 Lockable switches „ON-0-REMOTE“ 1P 16 A
- 1 Mushroom-head button „EMERGENCY STOP“
- 2 Signal lamps 230 V LED „OFF“
- 1 Built-in socket J15, 3P+N+E
- 1 Built-in socket CEE 16 A 400 V 6P+E
- 19 Terminals
- 6 Screwed cable glands M20/M25

Item 50710 pale grey

### Type 7750

Sizes 336 • 370 • 162 mm

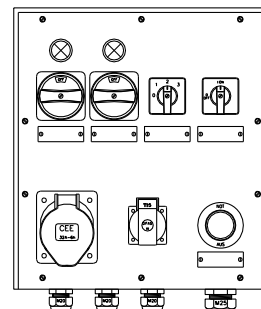

**Component**

- 1 Switch „0-I“ 1P 16 A
- 1 Switch „0-1-2-3“ 1P 16 A
- 2 Lockable switches 0-I 3make+1break 16 A
- 2 Signal lamps 230 V LED „OFF“
- 1 Mushroom-head button „EMERGENCY STOP“
- 1 Built-in socket type 15 10 A 400 V
- 1 Built-in socket CEE 32 A 400 V
- 24 Terminals
- 4 Screwed cable glands M20/M25

Item 50711 pale grey

### Type 7400/7450

Sizes 532 • 370 • 133 mm

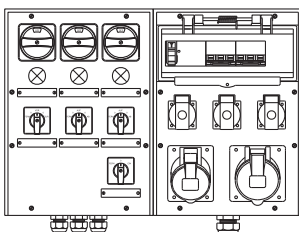

**Components**

- 2 Built-in sockets type 13
- 1 Built-in socket type 15
- 1 Built-in socket CEE - 16 A
- 1 Built-in socket CEE -32 A
- 1 FI switch 3N 40 A 30m A
- 1 Automatic breaker 3P 13 A
- 1 Automatic breaker 3P 16 A
- 3 Lockable switches „REMOTE-0“ 1P 16 A
- 3 Signal lamp 230 V „OFF“
- 1 Switch „REMOTE-0-FORWARD-0-BACK“ 1P 16 A
- 2 Switches „REMOTE-0-UP-0-DOWN“ 1P 16 A
- 1 Switch „REMOTE-0-ON“ 1P 16 A
- 4 Screwed cable glands 3xM20/1xM25

Item 58639 pale grey

## Steel supports/consolas

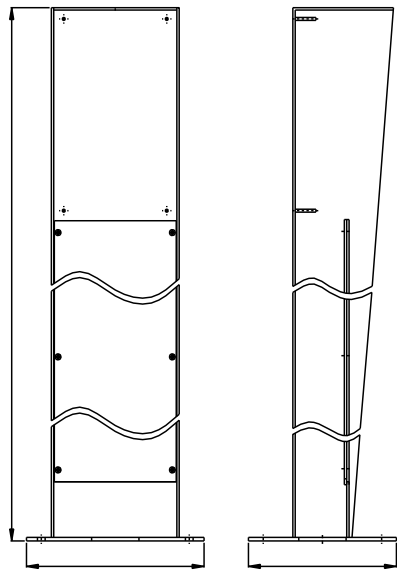

Type KA

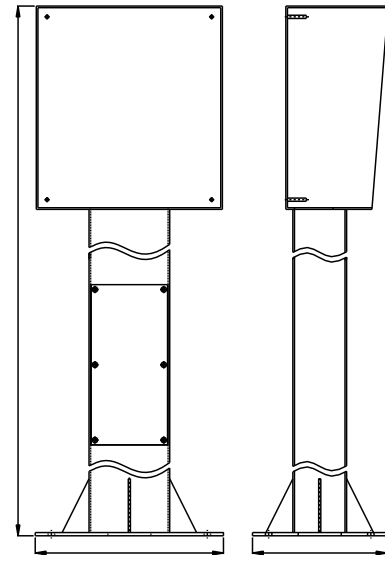

Type DE

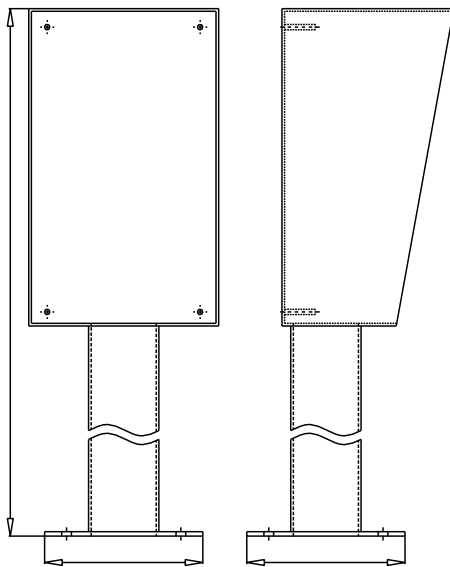

Type GE

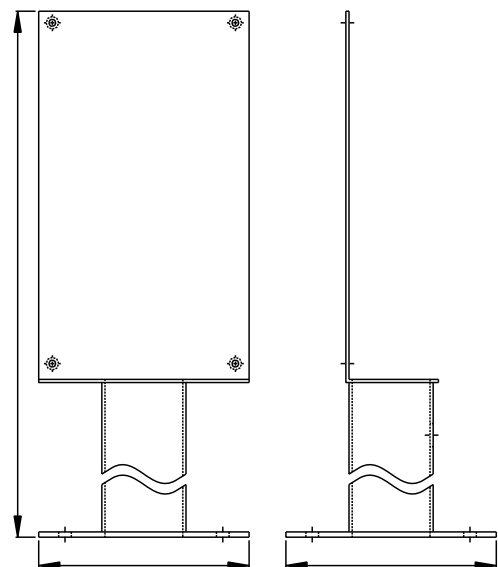

Type OF

With steel supports or consoles in different designs, the on-site combinations can be installed at the correct location as well as being protected against mechanical damage and the effects of the weather. **The steel constructions are powder-coated, zinc-plated or manufactured from rust-free material in V2A or V4A.** In collaboration with experienced technicians and metal engineers we develop the right design for you, tailored to fit the various hard rubber casings.

**Example specifications:**

Steel console type **KA** (Gifas-Electric), **V2A glass-blasted**, to fit on-site combination type **7350**, overall height **1400 mm**.

# Snapping-in emergency shut-off switch / motor protection switch



**Type 1010** Sizes 100 • 100 • 65 mm

**Type 1616** Sizes 160 • 160 • 90 mm

## Snapping-in emergency shut-off switch with notch

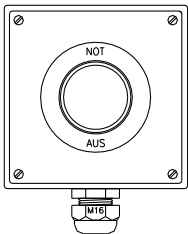

Item 30130 black  
Item 50729 pale grey  
Pressure operation/strain unlock red

Item 30132 black  
Item 50730 pale grey  
Unlock by turning, red

Screwed cable gland M16

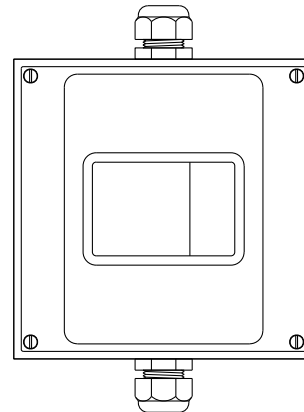

## Motor protection switch

Rated output of three phase current motors  
50/60Hz according to usage categories AC-3

Item	Colour	400 V/kW	Setting range of the therm. activation	Magnetic activation current
49702	black	0,25 - 0,37	0.63 -1.00 A	13 A
49703	black	0,37 - 0,55	1.00 -1.60 A	22 A
49704	black	0,75	1.60 -2.50 A	33 A
49705	black	1,10 - 1,50	2.50 -4.00 A	51 A
49706	black	2,2	4.00 -6.30 A	78 A
49707	black	3,00 - 4,00	6.00 -10.0 A	138 A
49708	black	5,5	9.00 -14.0 A	170 A

Screwed cable glands: 2xM20

### Additional modules:

- 49710 Auxiliary switch, no delay, side 1make+1break
- 49711 Locking device for padlocks in „O“ switch position.

**Type 1010** Sizes 100 • 100 • 65 mm

## Snapping-in emergency shut-off switch with notch

### „overload protection“

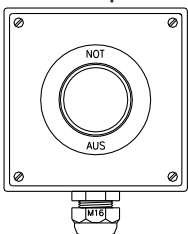

Item 30136 black  
Item 50731 pale grey  
Unlock by turning, red

Screwed cable gland M16

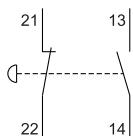

**Your specific requirements?**  
Allow us to offer you a custom-built solution.

## Practical examples

---



# Practical examples

---



## Practical examples

---



## Practical examples

---



# Get in touch with us

We are looking forward to become acquainted with you personally!



News about the  
assortment and  
specific solutions  
you can find  
on our website:

[www.gifas.ch](http://www.gifas.ch)

Energy in the right dimension

**GIFAS-ELECTRIC GmbH** Telefon +41 71 886 44 44  
Dietrichstrasse 2 Fax +41 71 886 44 49  
Postfach 275 www.gifas.ch  
CH-9424 Rheineck gifas.electric@gifas.ch

