

Client: Verkehrsbetriebe Zürich
Task: Illumination of the escape route in a tramway tunnel,
for case of emergency or maintenance
Object: Tramway tunnel Schwamendingen

Illumination of the escape route in a tramway tunnel



The optical control equipment in LED technology is not only applicable in road tunnels. The possibilities are very different and the application practically unlimited.

In this context and in cooperation with VBZ (public transport services of Zurich) we have developed LED modules suitable for the installation in a tramway tunnel of the VBZ.

Request / situation

The tramway tunnel Schwamendingen with a length of 2,5 km, has 3 subterranean stopping points and should be equipped with an illumination of the escape route to serve above all as orientation illumination.

In order to minimise the risk of accidents of the tramway- and maintenance personal, the lamps are switched-on during the repair-, maintenance- and control works on the tracks, e.g. the illumination is switched-off during the regular train runs.

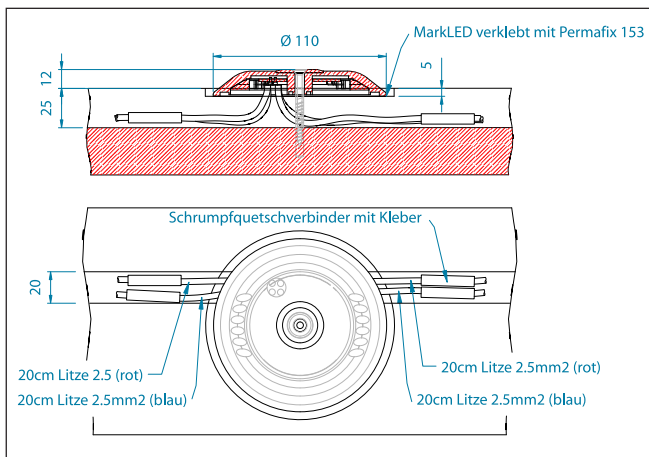

Installation principle:

- The LED modules are delivered encapsulated with 2 pigtails, 2,5 mm²
- The plumbing technology is absolutely sealed (cable and module)
- Equipped on 2 sides with 6 high-power LED

Advantage:

- increased security: risk to stumble, hard shoulders, kerbstones etc. are efficiently illuminated
- Aesthetic directed lighting
- Comfortable, bright white light (dazzle-free)
- Little current consumption due to the latest LED technology

