



Mobile floor distributor boxes, hard rubber

Features

The mobile floor distributor boxes range was designed for more complex, temporary construction sites. Varied component fitting options, robust casing design and a design matched to fit the application are the main features of this range.

With the mobile floor distributor boxes from GIFAS-ELECTRIC you get a long and durable service life with low maintenance requirements, even under the most extreme conditions. All requirements in terms of safety are also met in full.

Technical features

Hard rubber:
fully insulated, impact resistant, UV resistant, halogen-free, aging and temperature resistance, oil-and acid-resistant, fire resistant, self extinguishing, good chemical resistance.

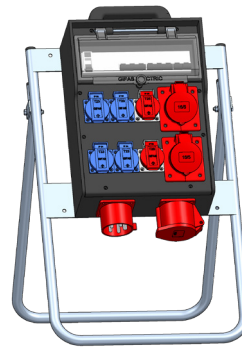
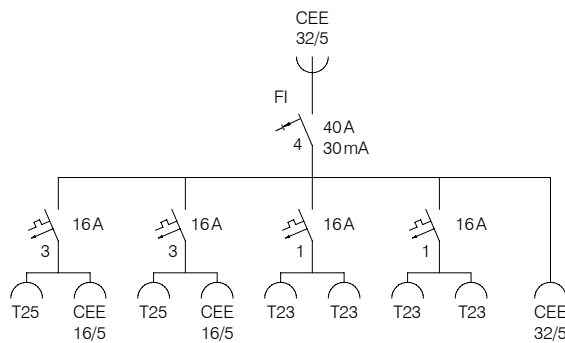

Item no.	Description
146122	Mobile hard rubber distributor type 7400, black, with steel stand V2A

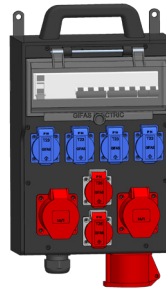
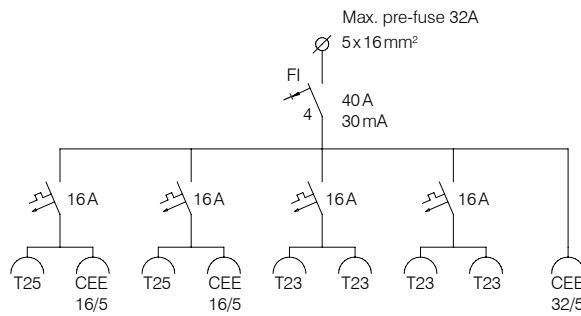

Item no.	Description
155858	Mobile hard rubber distributor type 7400, black, with 1 cable gland M32

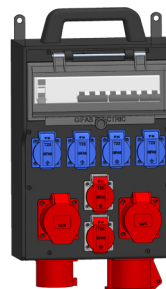
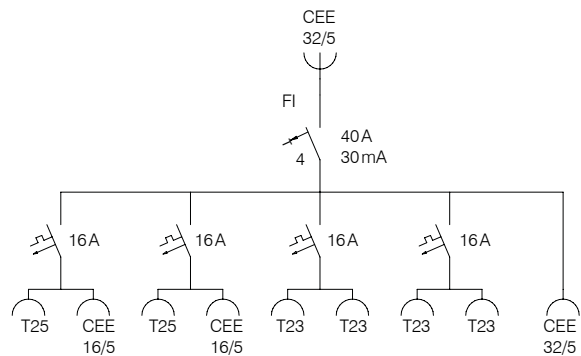

Item no.	Description
161762	Mobile hard rubber distributor type 7400, black, with 1 connector plug CEE32/5

Switchgear combination type 7400

Features

Thanks to our power distributors electrical power is available everywhere and without complicated installations! As with all products we give great importance to high quality components and workmanship. GIFAS hard rubber distributor boxes provide excellent technical characteristics.

Technical features

Hard rubber: fully insulated, impact resistant, UV resistant, halogen-free, aging and temperature resistance, oil-and acid-resistant, fire resistant, self extinguishing, good chemical resistance.

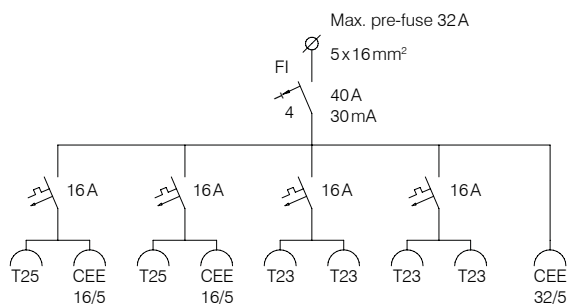

Item no.	Description
162665	Hard rubber distributor type 7400, black